

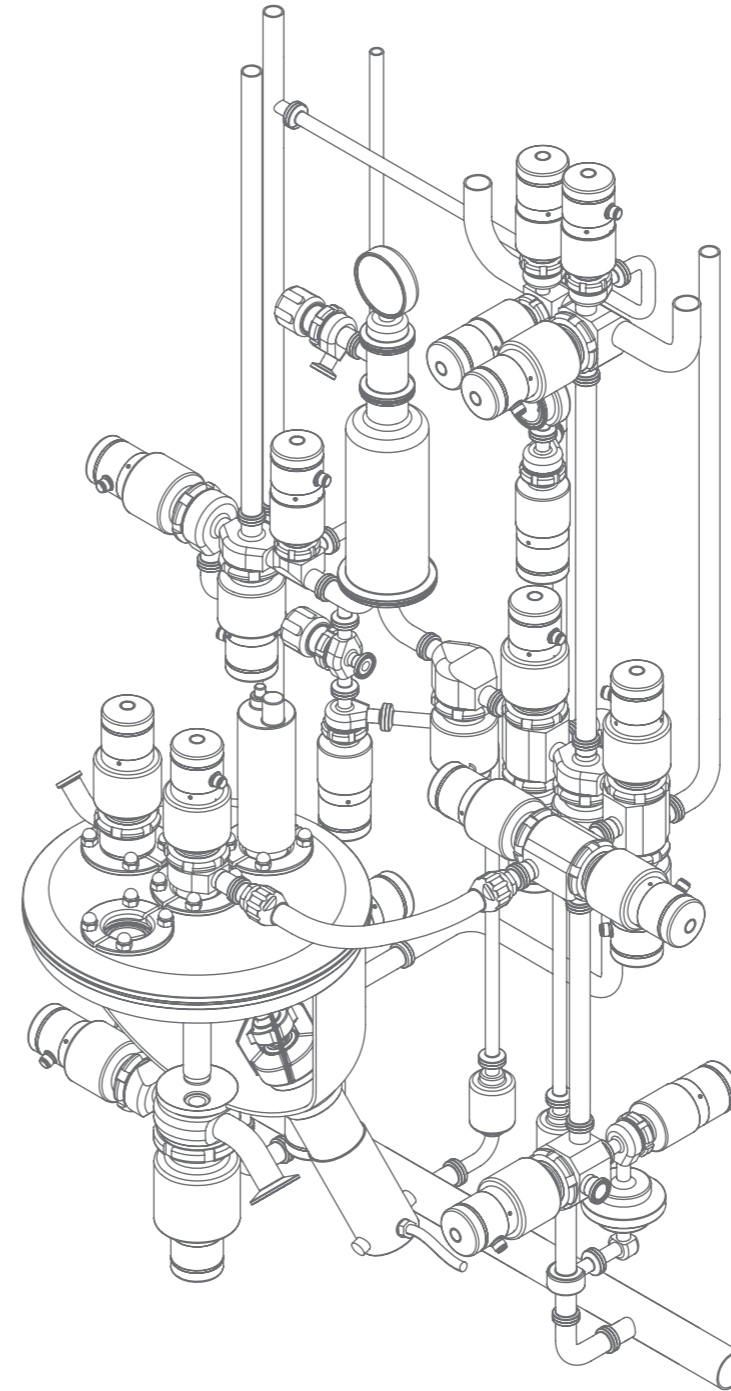

# INNOVATIVE SOLUTIONS FOR ASEPTIC PROCESSING

**CAD**  
CLEAN & ASEPTIC DESIGN

 **RATTINOX**  
ASEPTIC EQUIPMENT - DESIGN & SUPPLIER



# INNOVATIVE SOLUTIONS FOR ASEPTIC PROCESSING

**CAD**  
CLEAN & ASEPTIC DESIGN



# ONE IDEA, MANY SOLUTIONS

INNOVATIVE VALVE WITH ZERO DEAD LEGS

## INTRODUCTION

### CAD Clean & Aseptic Design: One idea, many solutions.

The CAD valve range is the key tool to help you easily satisfy critical aseptic processing criteria.

Frustrated with poor performing hygienic valves, aseptic process designers are asking for equipment to be able to fulfil the most stringent requirements of CIP and SIP. CAD valves are designed to answer these demands with properly designed process configurations upstream, downstream and around process vessels. The family of CAD valves offer designers a wide range of engineered solutions in order to realize compact designs, free of dead legs, with minimal solution hold up. Processing with CAD valves, which are constructed of 2 materials only: EN 1.4435-BN2 and PTFE USP Class VI-121°, will provide you an efficient process system, simple, reliable, and easy to validate.

### CAD valves benefits:

- Optimized CIP-SIP Cycles
- No unused portions
- Flush flow design
- Easy process Validation
- Wide range of design possibilities to meet unique applications
- Extensive technical documentation for Validation

**Valve design range:** the CAD family valve range is extensive. Our specialists in process design will support you in selecting the appropriate type. We can also help you optimize your solution preparation system in order to achieve a design free of unused portion piping and zero dead legs, with minimal product hold up in a compact design with fast and effective CIP and SIP cycles.

**Standard preassembled valves:** a variety of valve assemblies are available to speed up process construction. Point of use, bottom drain point, and others are available as standard products.

**Tailored valves and valves assembly:** if required, our specialists are able to quickly design, build and delivery special valves or assemblies.

**Support:** this guideline will help you with the correct valve selection and suggest alternative solutions according to your needs. The goal is to improve general performance in terms of effective cleaning (CIP), sterilizations (SIP) and full drainability. For additional information or support feel free to contact us at [info@rattinox.com](mailto:info@rattinox.com) or call the nearest Official CAD Distributor by looking at our website: [www.rattinox.com/en/contact-us](http://www.rattinox.com/en/contact-us)

## CONVENTIONAL EQUIPMENT ISOMETRIC VIEW

Projects realized with classic weir style membrane valves require a large number of elbows and tees. These fittings have been developed to allow for orbital welding, requiring extended pipe for this procedure. The final project often results in larger installations with some unused portions and dead legs, reducing the final efficiency and performance of the systems in terms of temperature distribution, drainability and cleanability.

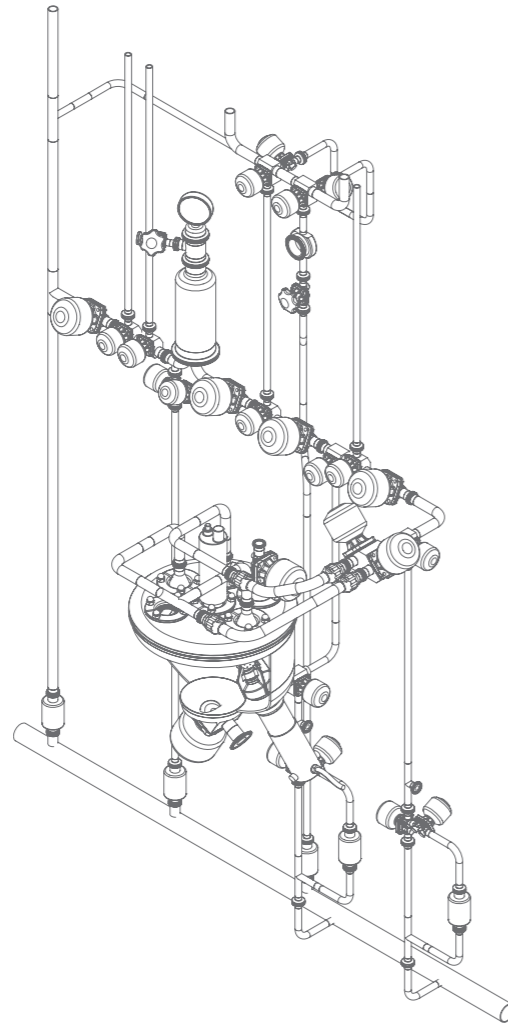

## CAD EQUIVALENT ISOMETRIC VIEW

Thanks to the CAD philosophy and the wide product range, the use of elbows or tees can be drastically reduced. The final project results in a very compact design with less piping which improves system performance, cleanability, sterilization and overall efficiency.

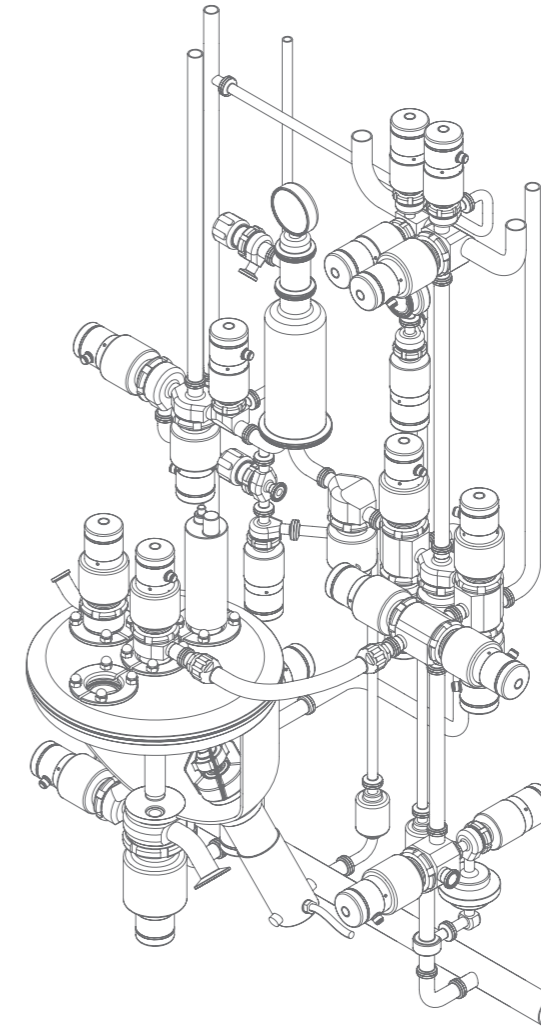

## CLASSIC EQUIPMENT P&ID

Typical P&IDs use unified symbols to identify the valves and components in an installation. Weir style valve symbols identify only a small list of bodies which sometimes leave interpretation to the builders which can result in incorrect valve selection.

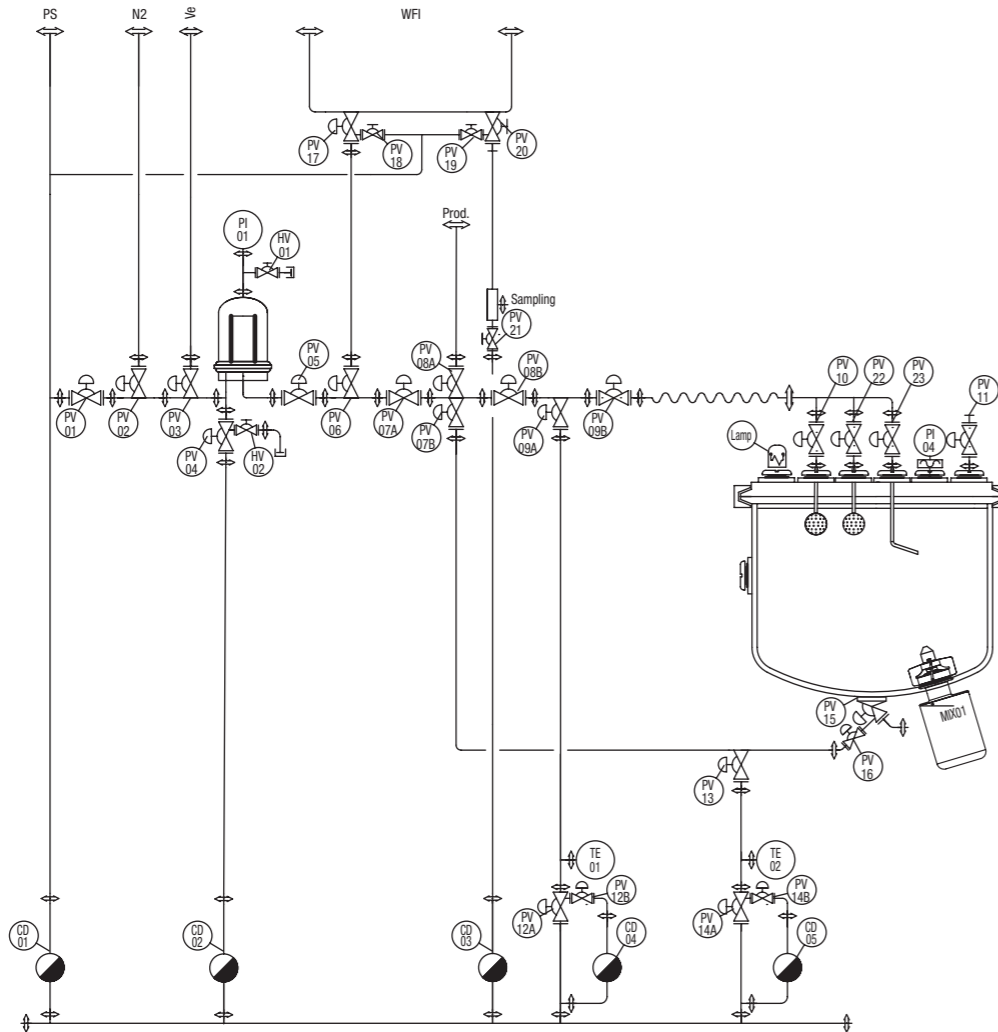

## CAD P&ID

Thanks to the wide CAD product range, it is possible identify immediately the required valve configuration, such as Shut off 90°, Shut Off 180°, Flow Through, On Pipe, etc... CAD valves have their own symbols. Our process experts will help you in the conversion from your classic P&ID to the CAD P&ID.

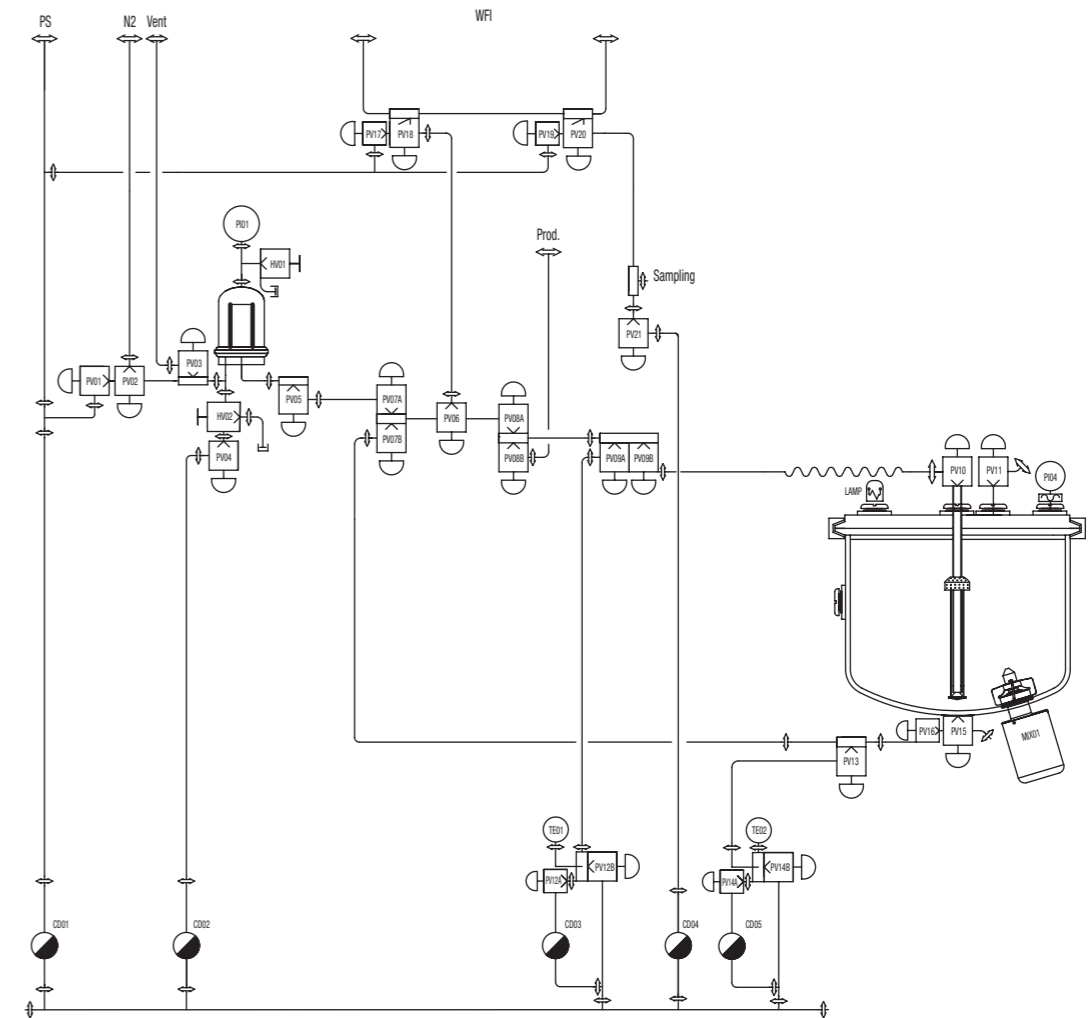

## Features analysis: ASYMPTOTIC SEALS

Two main factors affecting aseptic processing are CIP (Cleaning In Place) and temperature distribution for an effective SIP (Sterilization In Place). To achieve efficient and effective cleaning in place, a turbulent flow is required. The key point to achieving a turbulent flow is to avoid asymptotic closures.

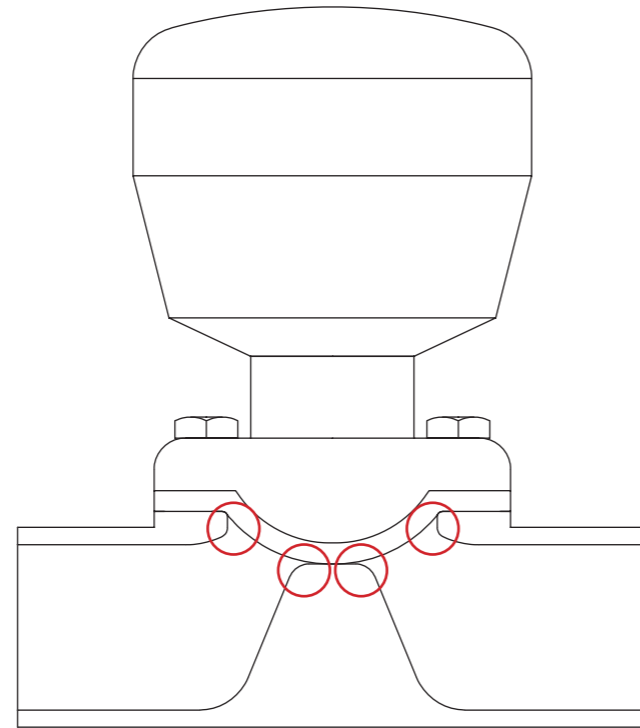
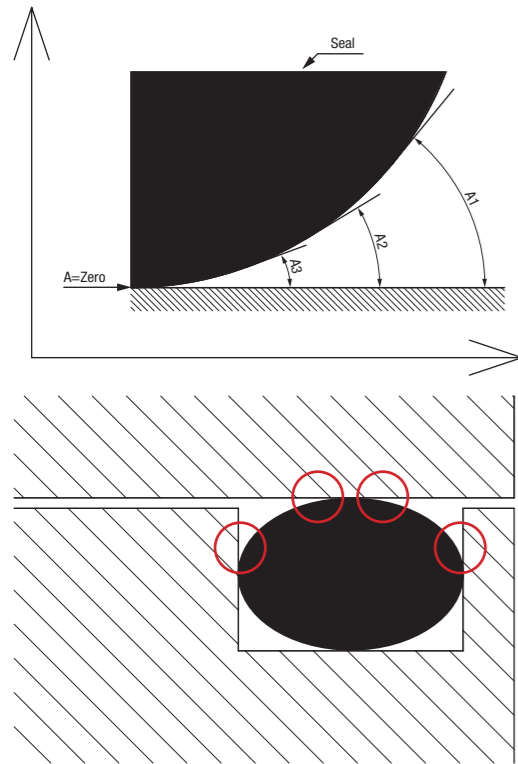

## CAD design: FREE FROM ASYMPTOTIC SEALS

Bioprocessing professionals more than ever require equipment able to efficiently fulfill the stringent requirements of CIP and SIP. The flush flow internal design of the CAD Valve, which is free from asymptotic closures and dead legs, is a key tool enabling you to guarantee critical criteria are easily satisfied.

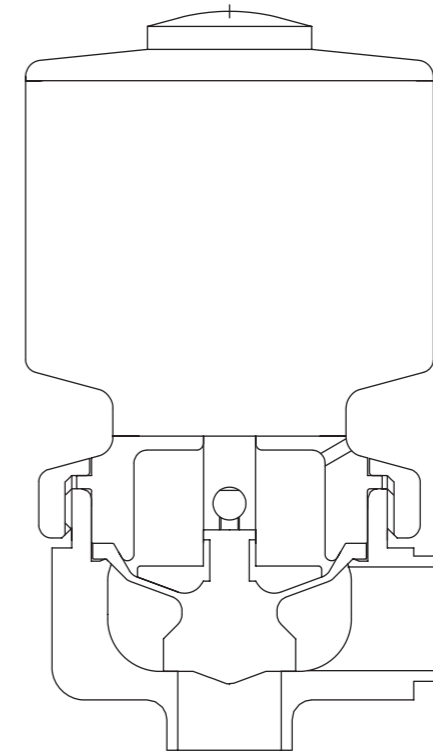



## Features analysis: DIAPHRAGM

Weir-style EPDM+PTFE backing cushion membranes, can have low resistance against vacuum resulting in a short life during SIP processes.

CAD valves were engineered from the beginning to address the most stringent requirements in terms of chemical compatibility and high temperature resistance.

For this reason the CAD valve was developed at the outset with solid compound PTFE Diaphragms without an EPDM cushion. This design has proven advantages in diaphragm life, resistance to steam and overall chemical resistance. CAD diaphragms are also able to run under vacuum conditions, required to speed-up drying processes after SIP cycles.

The engineered self-centering system allows the possibility to disassemble and reassemble the same diaphragm for inspection purpose, avoiding leakage at sealing points, typical of other PTFE diaphragms.

Example of conventional design



CAD design

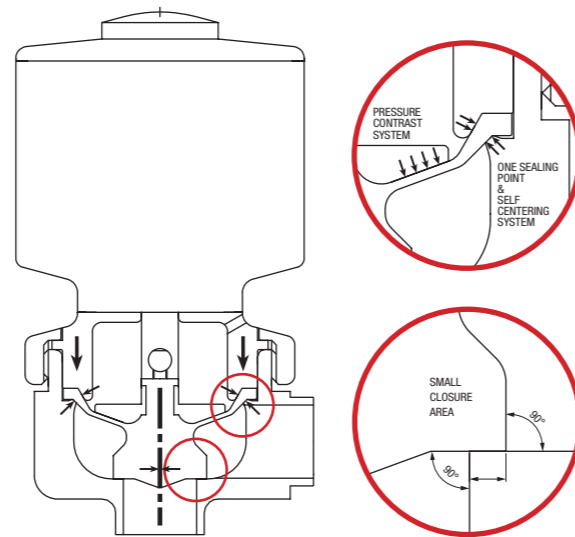

## Features analysis: FREE FORM BODY DESIGN

Valve with a straight body design require the use of additional piping such as elbows and tees during piping assembling which increase the distance between the inlet of the flow to the outlet of the valve.

Thanks to the radial design and the Smart Manufacturing System, each CAD Valve will follow all requirements in terms of single or multiple connections on the body reducing or eliminating additional fittings such as elbows and tees. This results in a very compact but serviceable design by reducing the number of component weldings and useless piping. The CAD product range is very extensive. Our process experts will help you choose the correct design to improve the performance of your systems. Full adaptability to engineering design is achieved: one idea, many solutions.

Example of conventional design

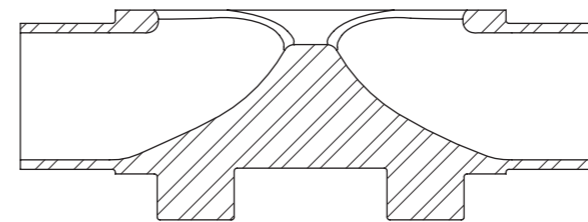

CAD design

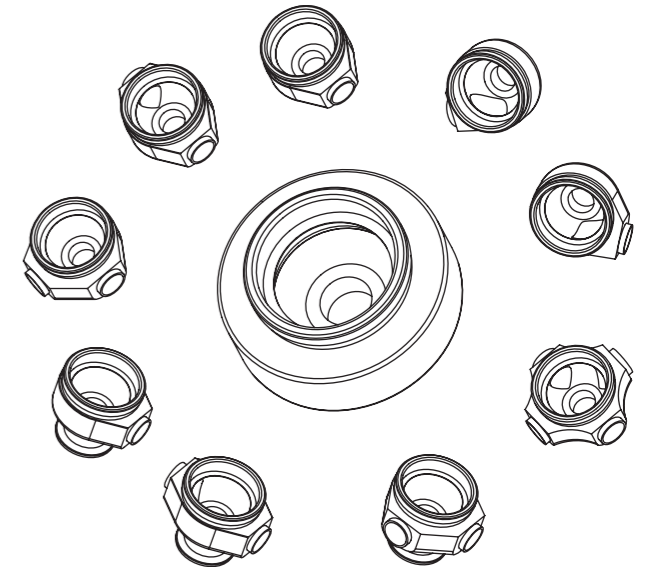

## PROCESS VALVES: SHUT OFF 90

The typical straight design of membrane valves are commonly used for hygienic industrial applications but their internal design, with asymptotic closures, will always have two long dead legs on the valve entrance and outlet. This is an important feature that may reduce performance of aseptic processing systems.

**CAD SOLUTION.** Radial design drastically reduces the distance between the inlet of the valve and the sealing area. During the assembly of a Shut-Off 90° valve, the distance between the valve inlet and the outlet is reduced and drainability is automatically improved. The internal design, free from asymptotic closure, improves the speed of CIP & SIP cycles while also avoiding in some cases disassembly for manual internal cleaning.

Example of conventional design

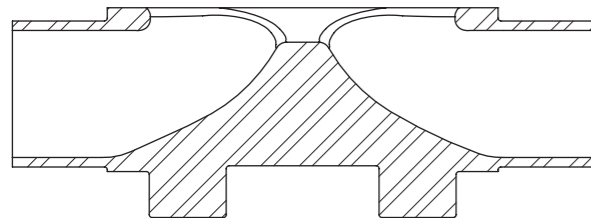

CAD design

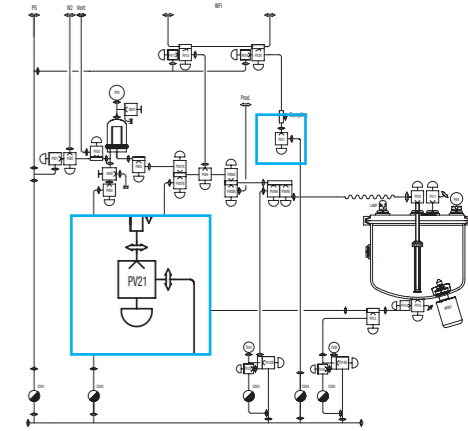
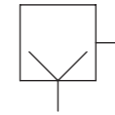
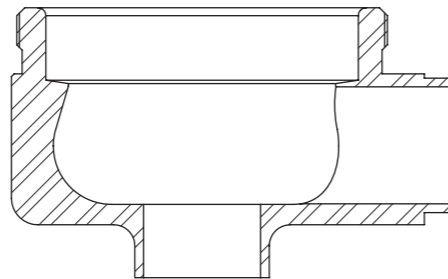

Internal design free from asymptotic closure

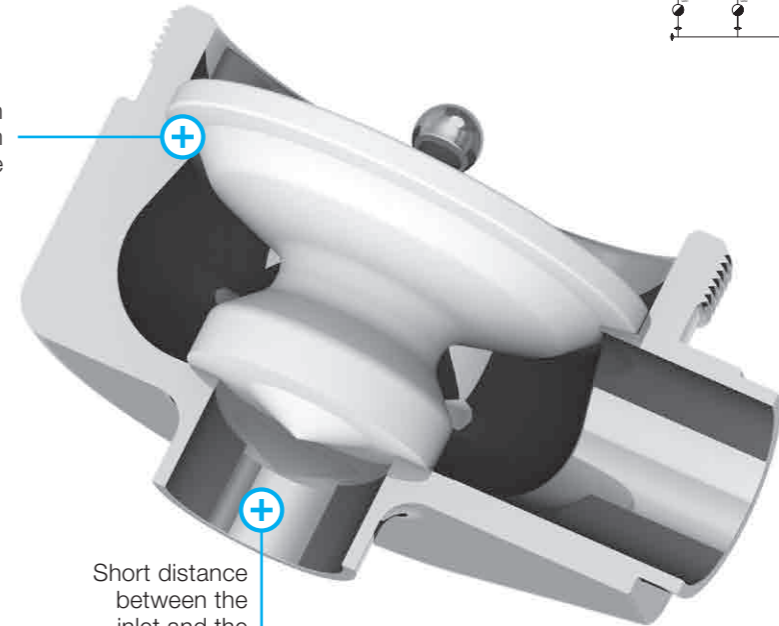

Short distance between the inlet and the sealing area

Standard CAD Valve body configurations examples: coaxial, eccentric, tangential.





## PROCESS VALVES: FLOW THROUGH 180

During the development of manifolds, tee fittings are usually needed, but this design will add one Dead-Leg for each valve connected. Dead-Legs result in reduced performances of CIP and SIP steps, incorrect temperature distribution, air pocket, etc...

**CAD SOLUTION.** The Flow Through design allows the flowing medium to cross and circulate inside the valve and inner part of the diaphragm. This area is always under flow, thus avoiding stagnant product inside the valve body. Thanks to the flush flow design of Flow-Through valves, the Dead-Leg between the closure area and the manifold main pipeline is a real ZERO Dead-Leg, not 3xD or 1,5xD. This design offers a great benefit in terms of cleaning and sterilization in CIP and SIP cycles. The typical body configuration body is 180° in/out. Also available as a standard design is the Flow-Through 90° valve as well as with tangential connections to avoid the use of elbows which result in product hold up.

Example of conventional design

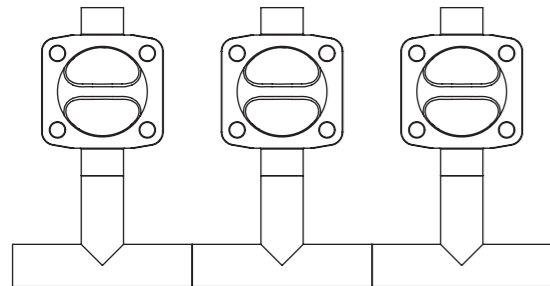

CAD design

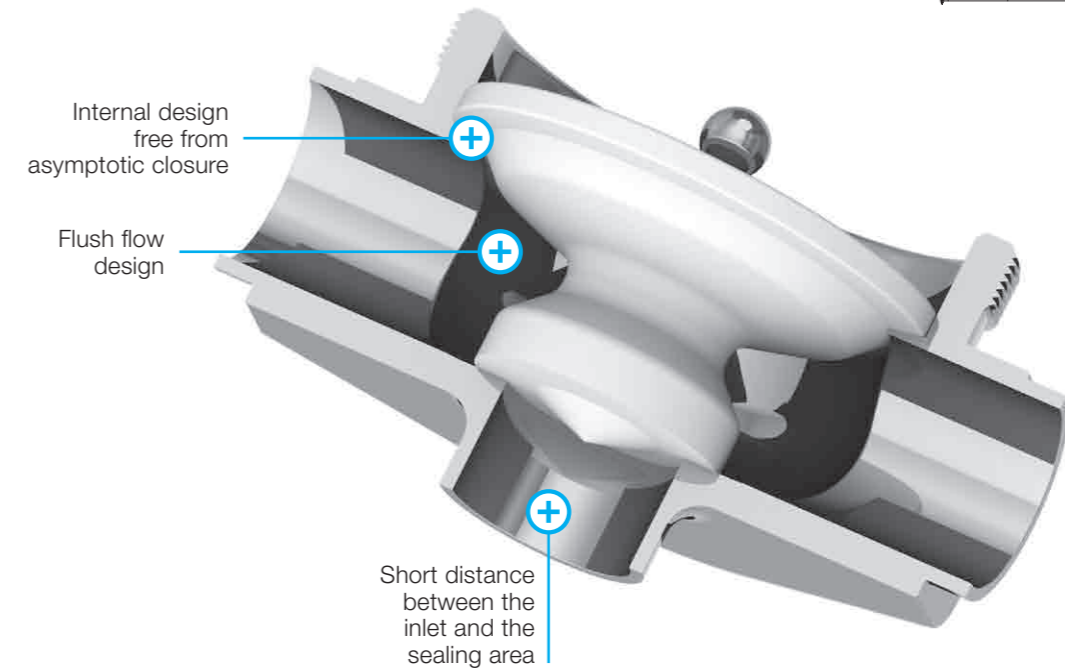
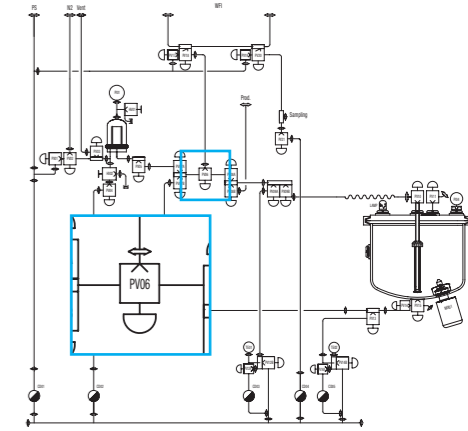
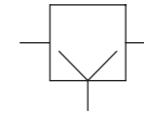
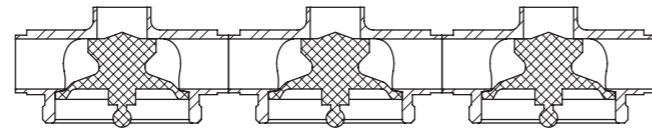

Standard CAD Valve body configuration examples: 180°, 90°.

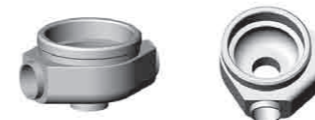

## BOTTOM TANK VALVES

Tank outlet valves of the weir design have significant limitations due to the fact that to achieve this application a larger diameter welding plate is needed. According to PED rules the thickness of the bottom dish needs to be increased to accommodate the larger cut out. In addition, the closure area has to be moved to a lower position to be able to accept the membrane sealing which results in a pocket on the internal side of the vessel. This pocket makes homogeneous mixing problematic and typically not acceptable for bioreactors.

**CAD SOLUTION.** CAD Bottom Tank Valves have been designed to follow the most stringent requirements for pharmaceutical vessels. Most importantly the closure area is positioned as close as possible to the internal side on the vessel without creating a pocket. In addition, the conical part of the valve inlet is open to the turbulence of the mixing unit reducing to a minimum the risk of deposits of suspensions in this area. The welding plate diameter can be minimized, allowing designers to reduce the dish thickness as much as possible according to PED rules.

Example of conventional design

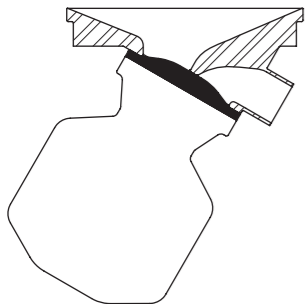

CAD design

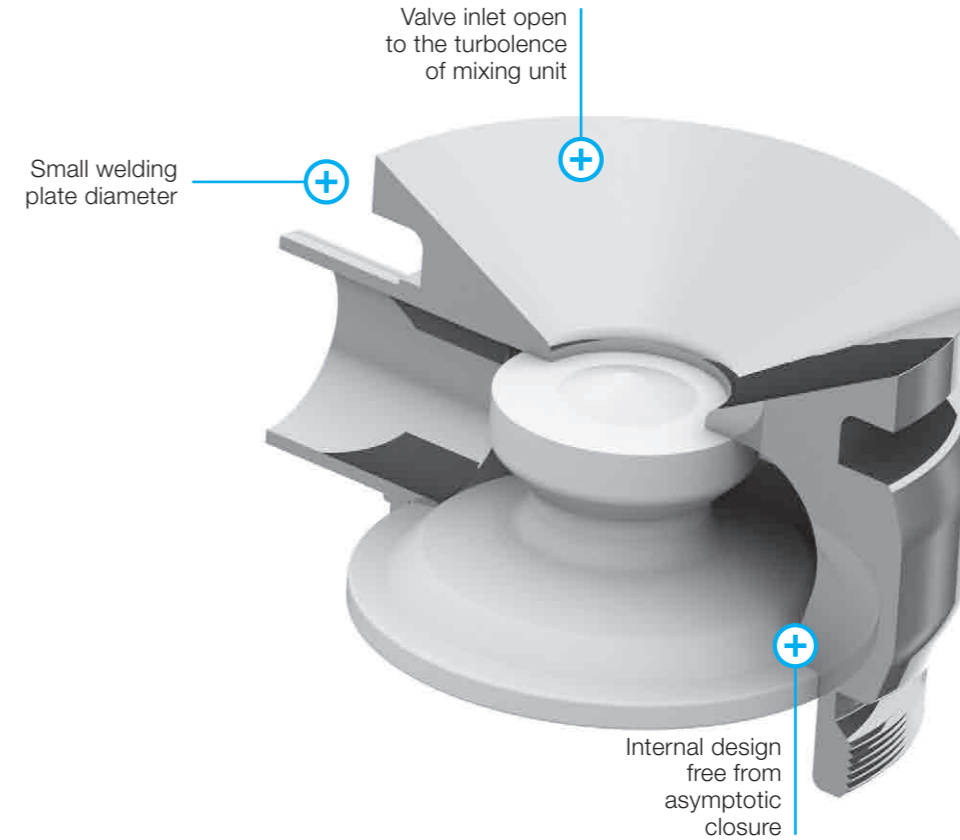
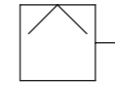
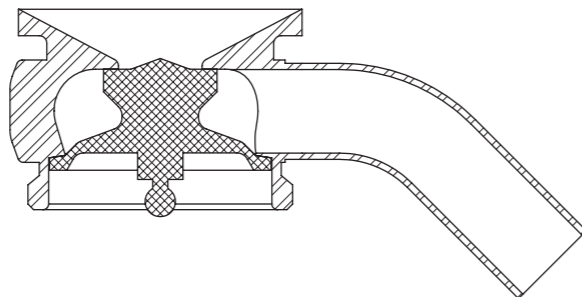

Standard CAD Valve body configuration examples: shut-off, flow through 90°, flow through 180°.



## BOTTOM TANK VALVES + SATELLITE

**CAD SOLUTION.** Important to aseptic processing design is the possible addition of satellite valves on a CAD Bottom Tank Valve. This feature allows the possibility to clean and sterilize downstream of the vessel before transfer of the product inside the vessel taking advantage of the ability to CIP downstream of vessel without loading CIP media inside the vessel. CAD Valves used in satellite applications are typically eccentric or eccentric as well as tangential. Eccentric valves reduce the ratio in correspondence of the entrance of the satellite valve on the bottom valve, reducing the dead-leg, allowing also the possibility to use larger satellite valve sizes to improve the quantity of water flow on CIP cycles inside the CAD Bottom Tank Valves. Thanks to the eccentric & tangential solution, the minimum distance required between the lower part of the vessel and the floor can be reduced, saving space against the room ceiling, and avoiding again the use of elbows at the entrance of the satellite valve.

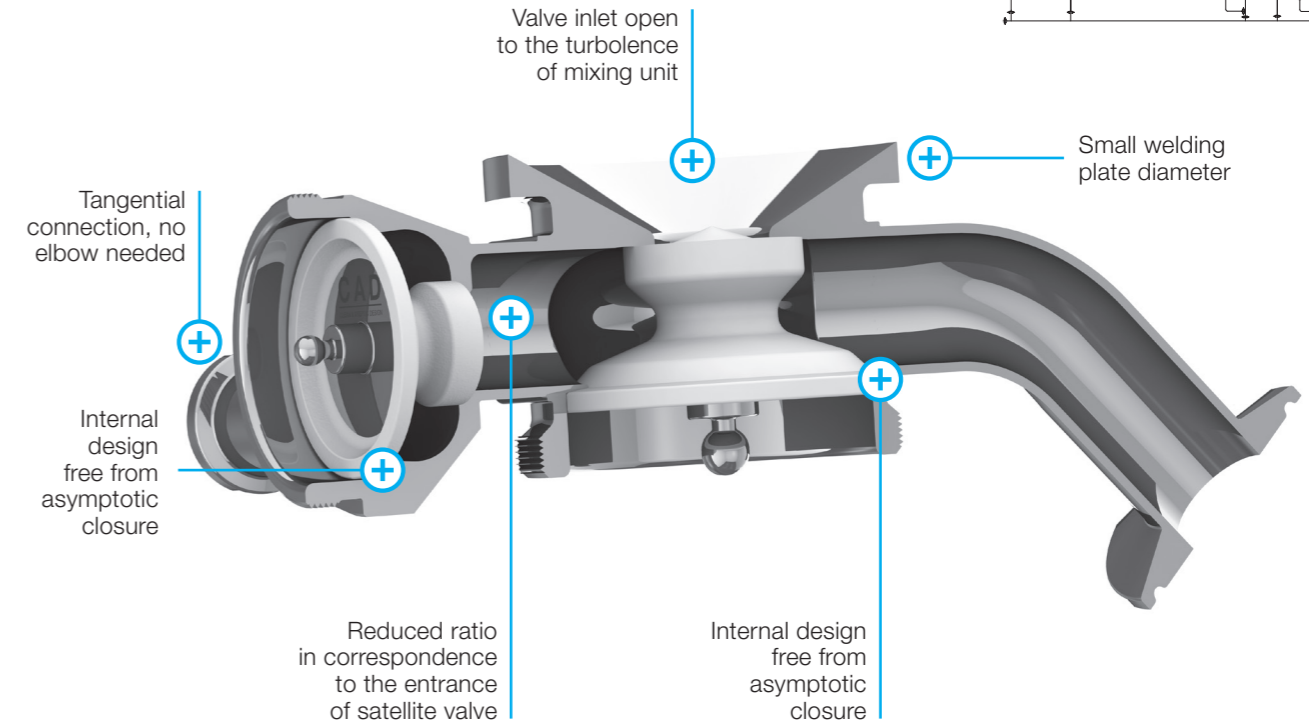
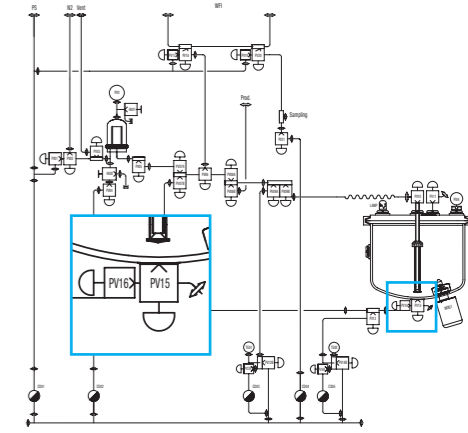
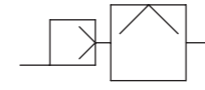
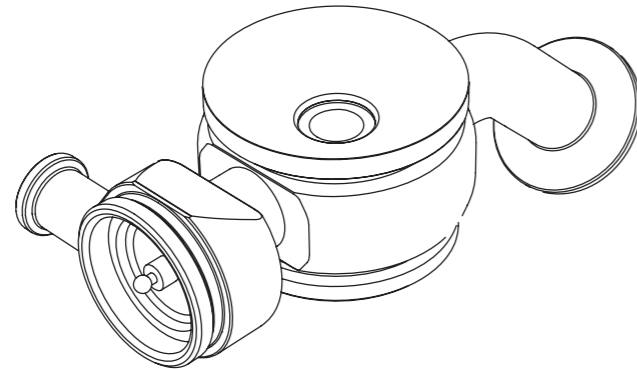

## BOTTOM TANK VALVES FOR JACKETED VESSELS

Usually vessels and fermenters for biotech applications require full body insulation to keep the internal side at a specific controlled temperature. Typically the jacket of the vessel on the lower side covers only a portion of the vessel bottom, but not the tank outlet valve, leaving the lower side of the vessel at a non-controlled temperature. This may result in a fermenting process that is hard to control or out of control.

**CAD SOLUTION.** Thanks to the CAD Bottom Tank Extended Valve Bodies, it is possible to weld the jacket over the valve body. The result is the valve and the entire vessel bottom can be insulated, eliminating a heat sink. This will result in a fully controlled temperature in the lower part of the vessel improving fermentation efficiency as well as use in MAB cryogenic storage vessels where maintaining vessel temperature is critical.

Example of conventional design

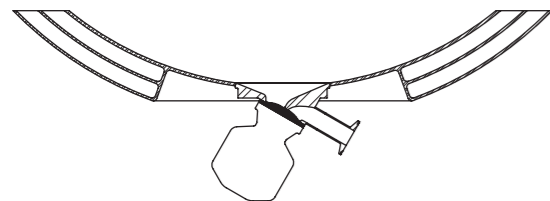

CAD design

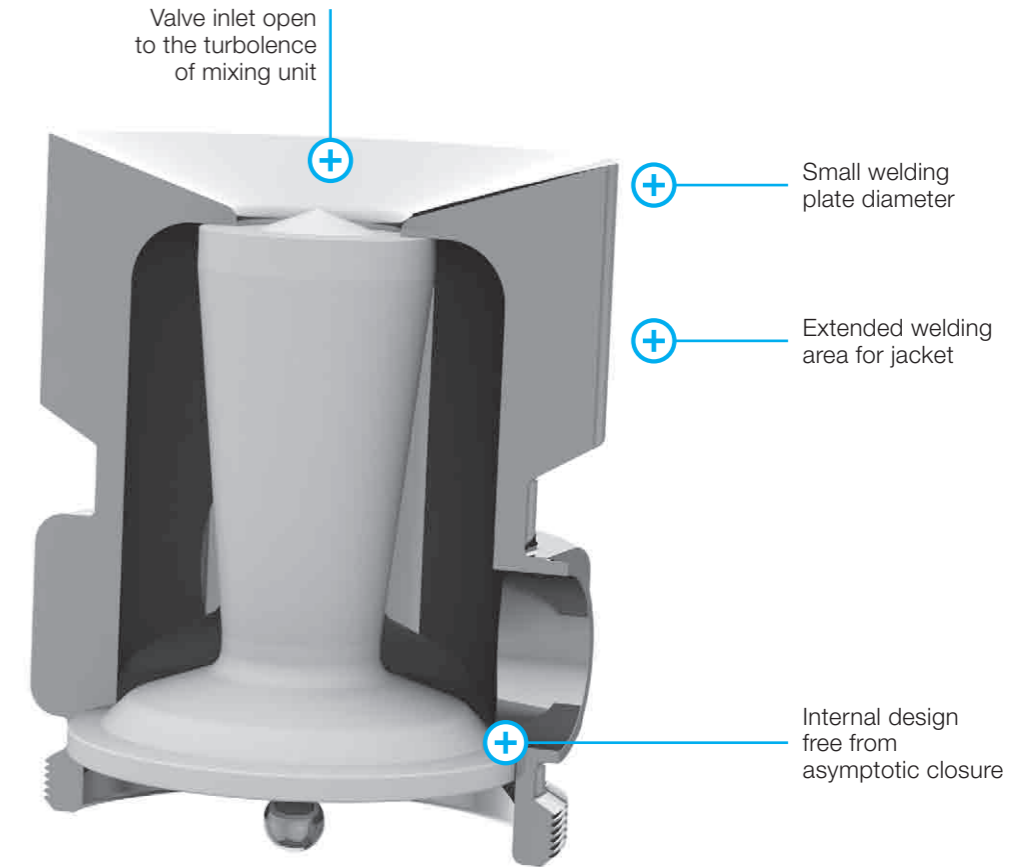
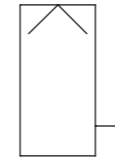
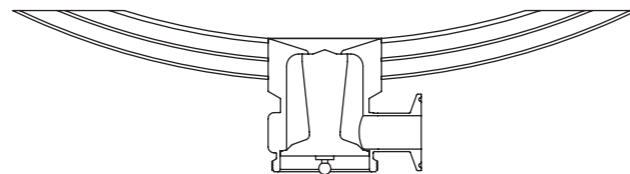

CAD standard bodies configurations examples: shut-off, flow through 90°, flow through 180°.



## BOTTOM TANK VALVES FOR JACKETED VESSELS + SATELLITE

**CAD SOLUTION.** The advantage for aseptic processing to fully control vessel temperature and allow for ease of downstream CIP/SIP can also be achieved on the lower part of bioreactors and other critical vessels. Thanks to the wide range of configurations of the CAD valves there is the possibility to add a satellite valve for downstream cleaning and sterilization of fully jacketed vessels.

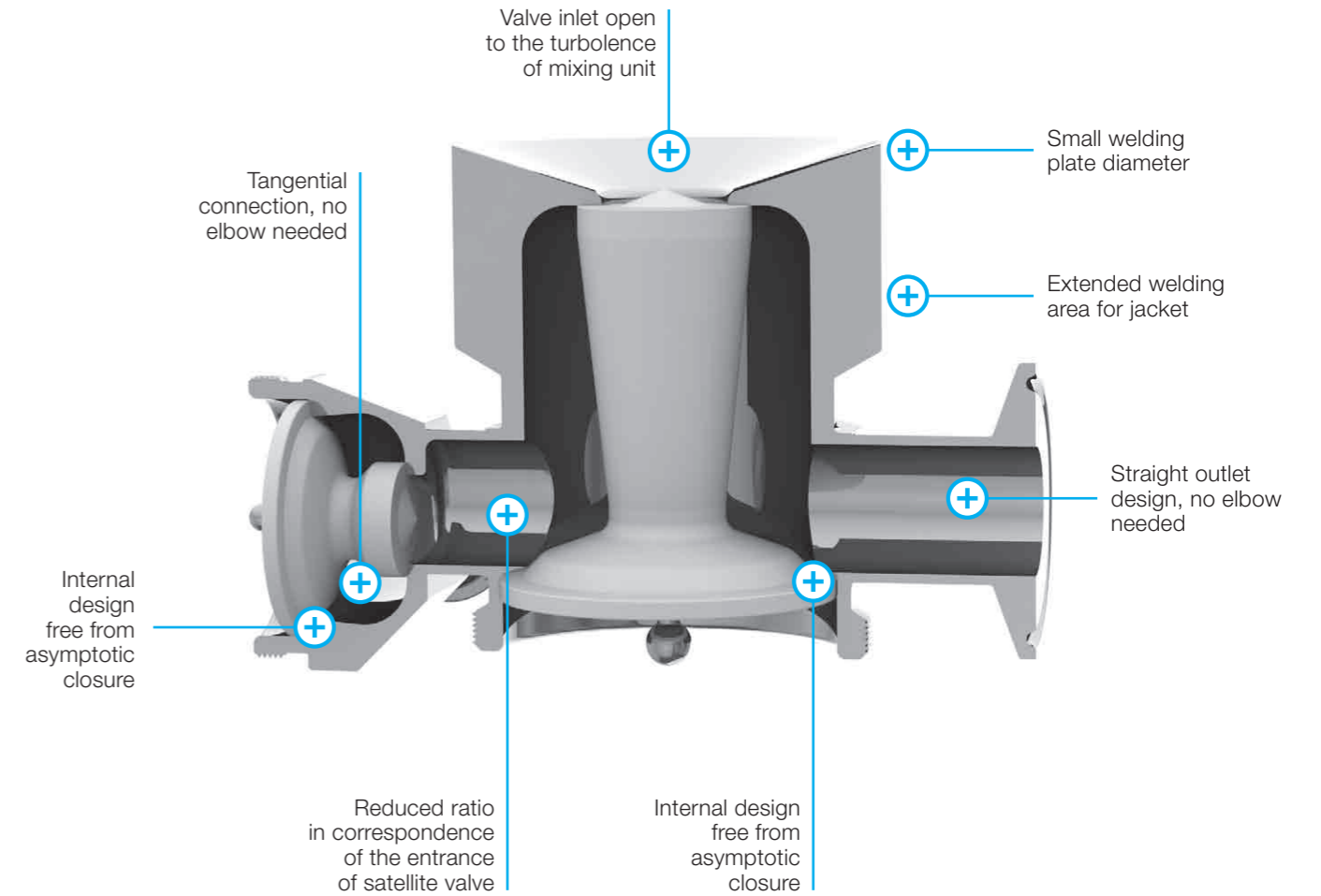
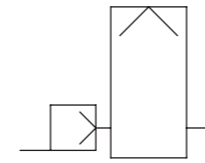
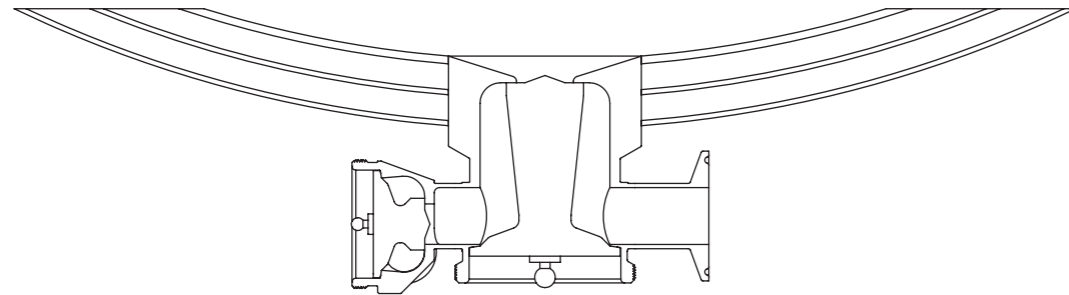

## TANK WELDABLE VALVES

Adding a valve on the top or on the side of a vessel requires a connection. Adding a connection such as a Tri-Clamp may result in a dead-leg that will may have problems in terms of internal cleaning and sterilization. Using CADCON welding plates there is the possibility to reduce the distance between the internal side of the vessel and the valve closure area. Sometimes, this is not still enough...

**CAD SOLUTION.** Thanks to the CAD Tank Weldable Valves, the distance between the internal side of the vessel and the valve closure area can be drastically reduced. This will have a great effect on CIP/SIP cycles of the vessel, by avoiding any dead legs. On request, the welding area of CAD Tank Weldable Valve can be machined according to the radius of the vessel, moving the valve closure area nearest to the internal side of the vessel. The manufacturing of the vessel will be easier and cleanability will be improved avoiding any disassembling operation.

Example of conventional design

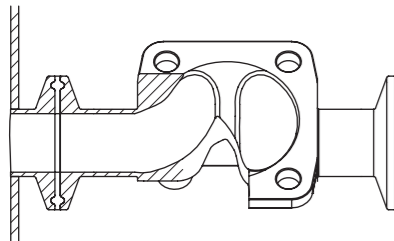

CAD design

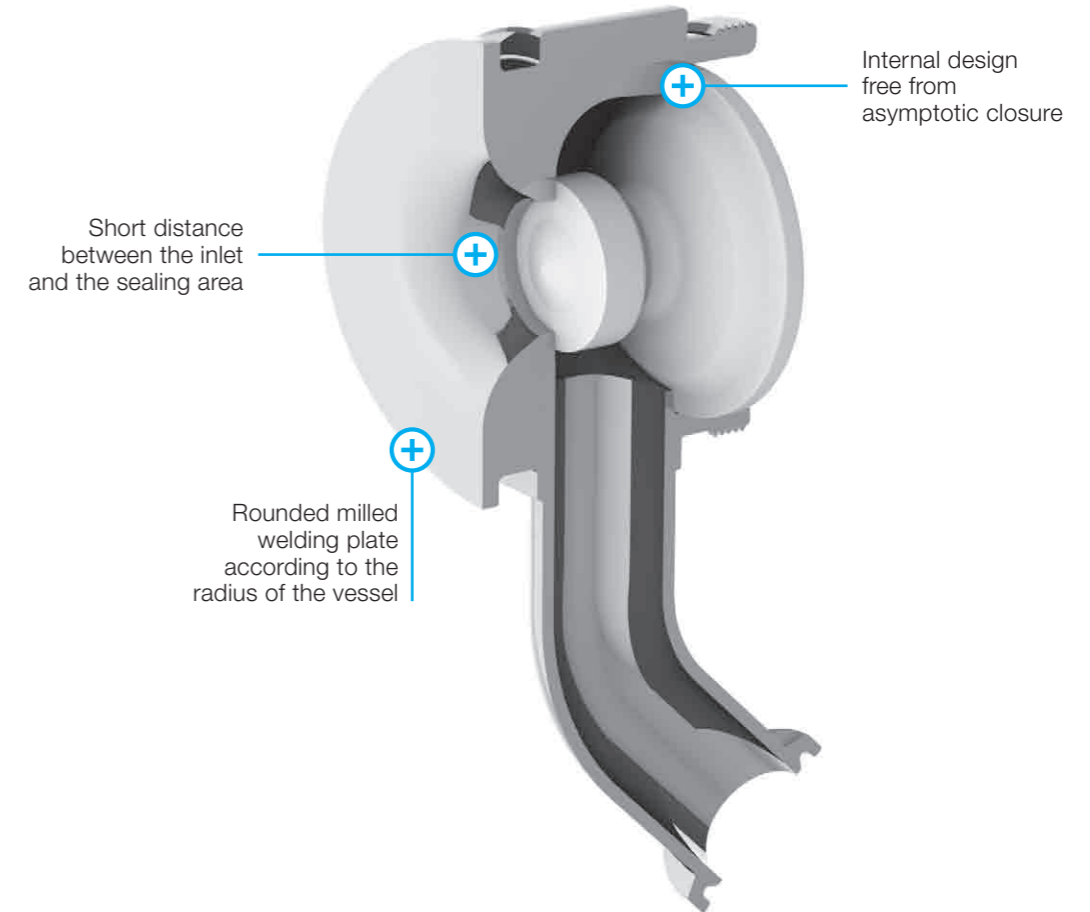
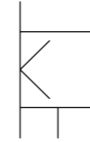
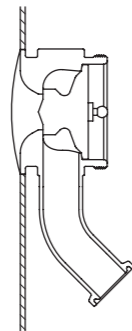

Standard CAD Valve body configuration examples: shut-off, flow through 90°, flow through 180°, with coaxial or tangential connections.





## TC CONNECTABLE - TOP MOUNTING

Each connection on the top of a vessel is a cleaning problem. Each connection requires additional attention during cleaning due to the fact that it has to be cleaned by the spray ball positioned inside the vessel. More connections equal more difficulty cleaning by CIP. If closure areas of valves mounted over the vessel cannot be reached by the spray balls, CIP will not be achieved and disassembling will be required for additional cleaning. Welding of Tri-Clamp ferrules and connecting a valve with a straight design, moves the closure area farther from the top of the vessel. Welding of a CADCON instead of a Tri-Clamp will reduce this neck, putting the Tri-Clamp sealing point in correspondence with the internal side of the vessel.

**CAD SOLUTION.** The easy solution to reduce dead legs on the top of the vessels is to transfer the valve closure area as close as possible to the internal side of the vessel. This is the most important reason for development of the CAD TC Connectable valves. A wide product range based on all CAD valve designs with Tri-Clamp connections already machined on the valve body is standard. These valves are ready to be connected to a CADCON connection which offers designers and operators complete flexibility. The valves are designed to avoid interference between the valve body and the bolts over the flange. For each valve size there are available many different valve designs such as Shut-Off, Flow Through, etc..., even with different Tri-Clamp sizes.

Example of conventional design

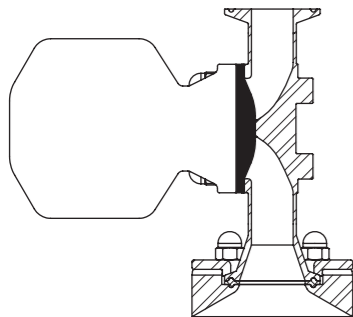

CAD design

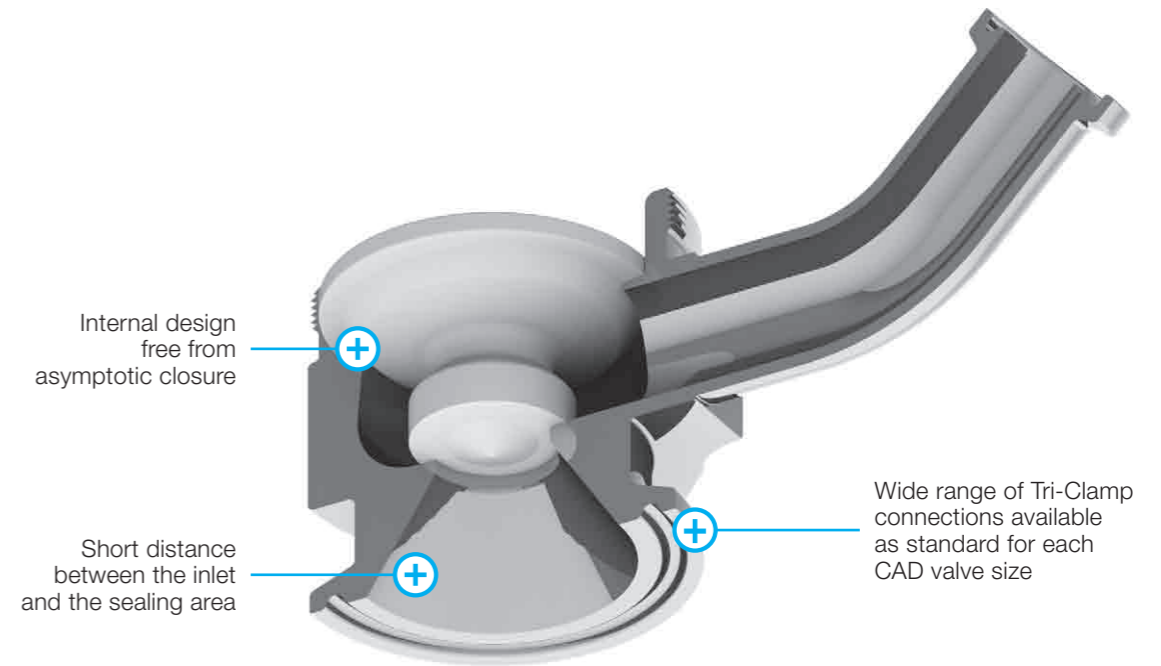
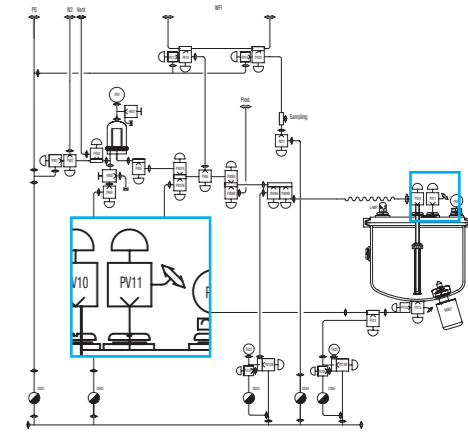
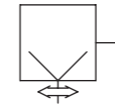
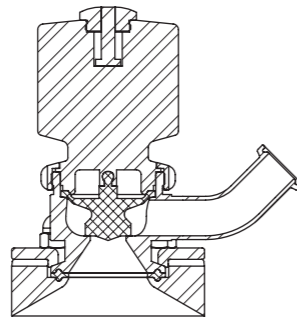

Standard CAD Valve body configuration examples: shut-off, flow through 90°, flow through 180°.



## EXTENDED TC CONNECTABLE LATERAL MOUNTING

Aseptic processing is like a chain: each component has to work properly. Even with one of the components not working properly will result in a final failure of the entire system. In case of a lateral connection on a vessel, any additional connections may cause a cleaning problem. Elimination or reduction of dead legs will improve cleanability and sterilization of the system. Welding of a noncleanable or a long connection will compromise the entire process.

**CAD SOLUTION.** CAD Extended TC Connectable valves, connected on a CADCON, will put the valve closure area very close to the internal side of the vessel, achieving the best condition to improve cleanability and sterilization of the vessel with additional benefit for all the process. Also Extended TC Connectable valves are available on all the CAD range design: Shut-Off, Flow Through 90, Flow Through 180, etc...

Example of conventional design

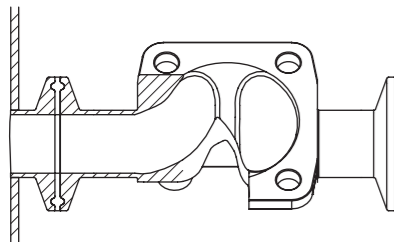

CAD design

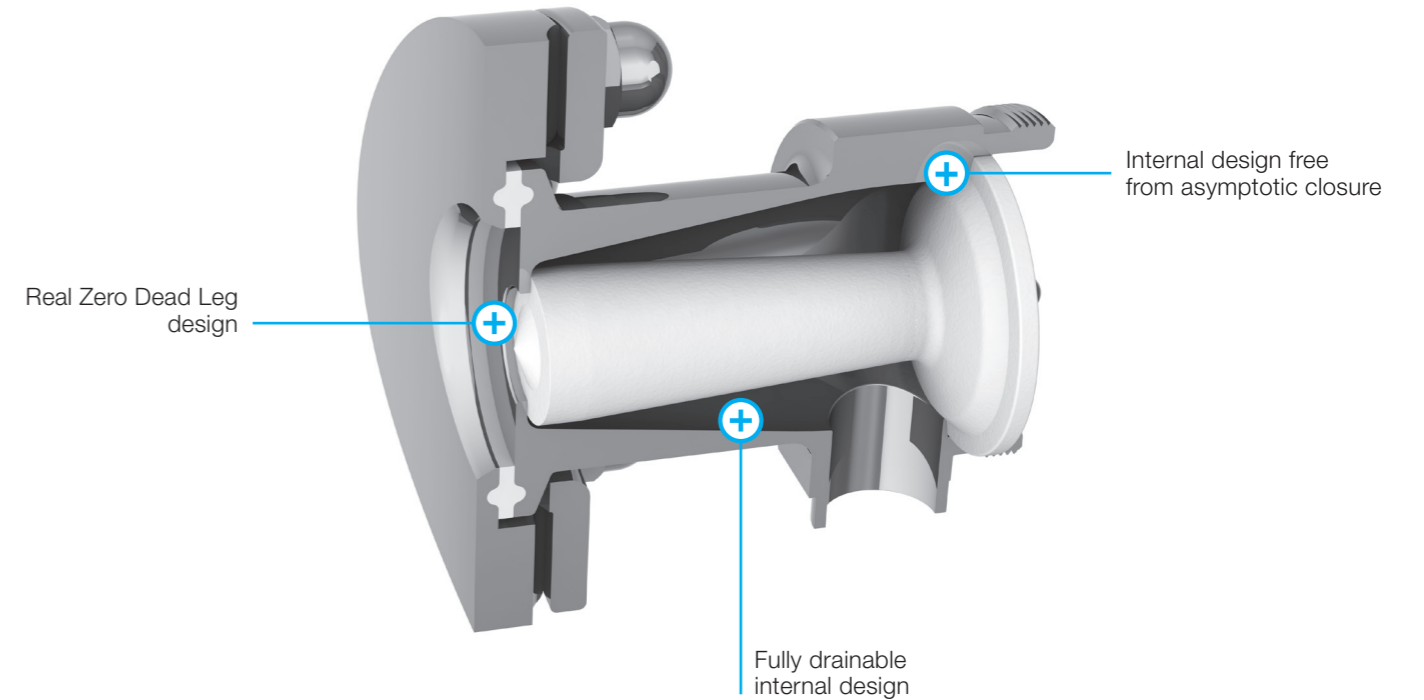
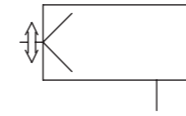
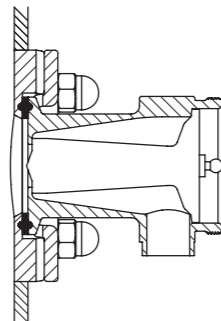

Standard CAD Valve body configuration examples: shut-off, flow through 90°, flow through 180°.



## DIVERTING VALVES

During Aseptic Processing it is often the case that the flowing media, whether product, CIP chemicals, clean steam or sterile gases, has to be properly managed through the system. Simply welding or connecting via Tri-Clamp two valves on a tee piece will result in 2 main negative effects: dead-legs and unused portions. Either situation can limit the drainability and thus the cleanability and sterilization of the system. This also increases the general dimensions and overall volume of the installation which can also reduce performance as well as increase maintenance costs.

**CAD SOLUTION.** CAD Diverting valves are the solution when the flow path has to be managed in different directions. The distance between the two closure areas are equal to the internal diameter of the common inlet pipe, achieving a very compact design, free of tee pieces or junctions. CAD Diverting valves are available as standard with 90° outlets or inlet which eliminates the need for many elbows. Several combinations are available in the catalog as standard but additional customized designs may be manufactured according to the demands of the process. Vertical or horizontal installation is not a problem. In the case where a horizontal installation is preferred, CAD Diverting valves are available with tangential outlets in order to achieve complete drainability of the valves. Two diverting valve connected between the common part is a typical configuration of a "Block and Bleed" assembly.

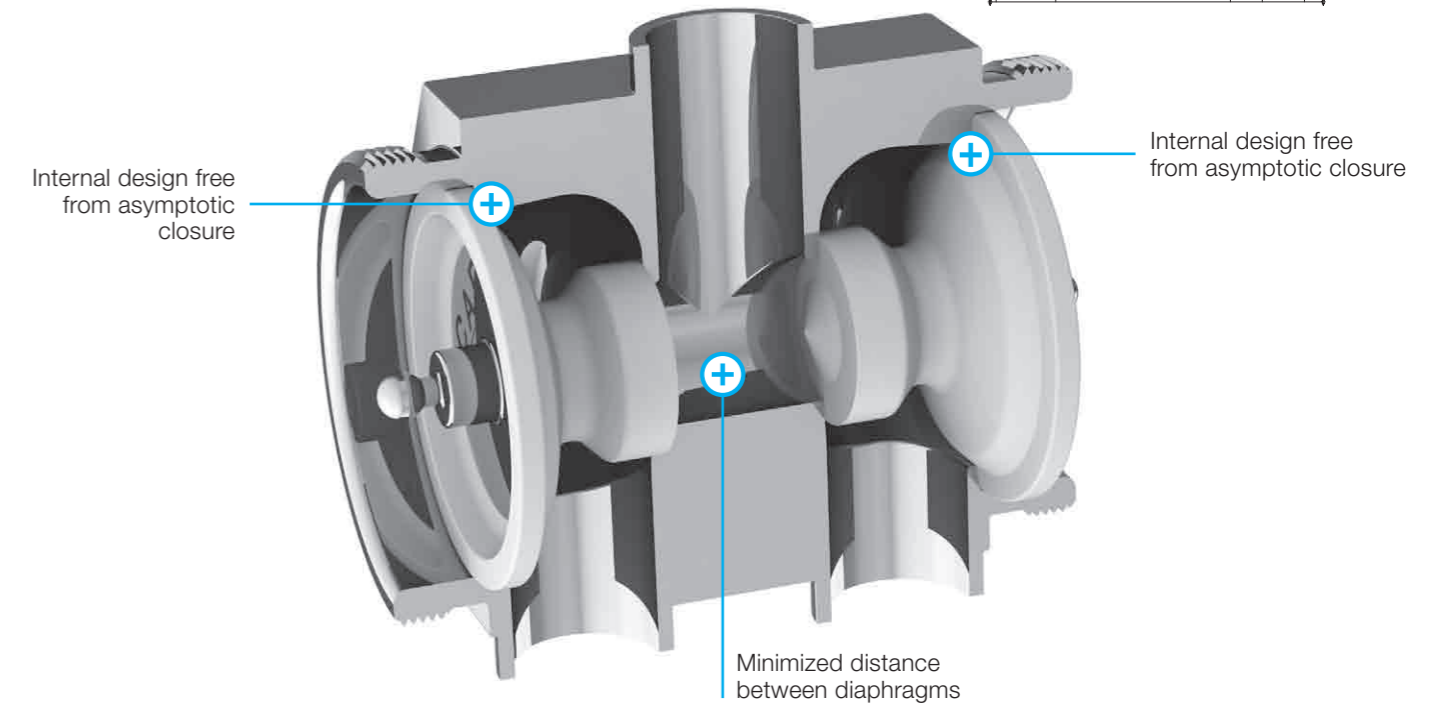
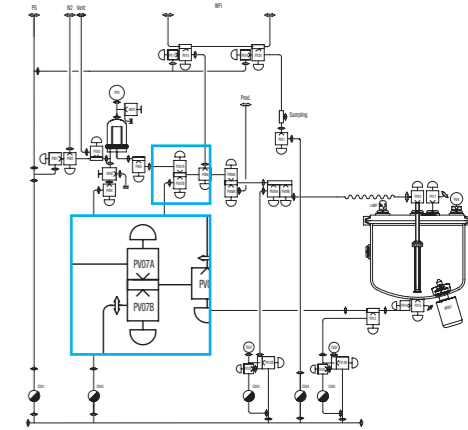
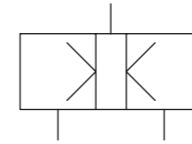

Example of conventional design

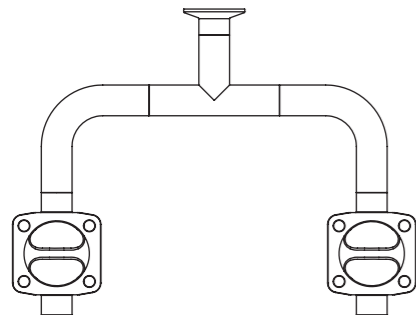

CAD design

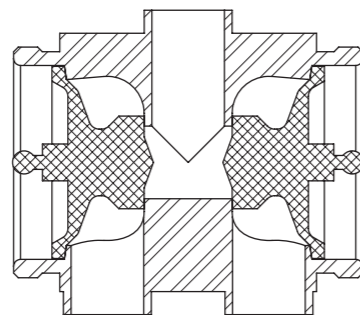

Standard CAD Valve body configuration examples: parallel, opposite, coaxial, tangential, 180°, 90°.



## VALVES ON PIPE - COAXIAL

Take-off or feed-in of a fluid on a pipeline is an additional key point because this requires additional connections on the main pipe with a dedicated valve. In this case the distance between the inner pipe and closure area of the additional valve has to be reduced as much as possible. Adding a tee piece will move this closure area farther from the main pipeline. This reduces the efficiency of the CIP or effect of SIP by creating an air pocket. To improve cleaning and reduce retention areas, an internal valve design free from asymptotic closures is an additional key point to achieving turbulent flow.

**CAD SOLUTION.** CAD Coaxial On Pipe Valves, respond to this requirement by putting the valve closure area in correspondence with the pipeline; like a finger that closes a hole on the side of a pipe: a real Zero Dead Leg design. Ideal for feed-in pipe, take-off or sampling from a pipe. The most stringent applications for WFI, PW loop or PS distribution piping can be easily managed. These valves are available in Shut-Off or Flow Through designs and also with additional satellite valves for downstream sterilization. If required, full drainability of the piping system can be achieved by connecting the valve in a vertical upside down orientation.

Example of conventional design

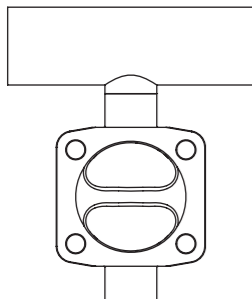

CAD design

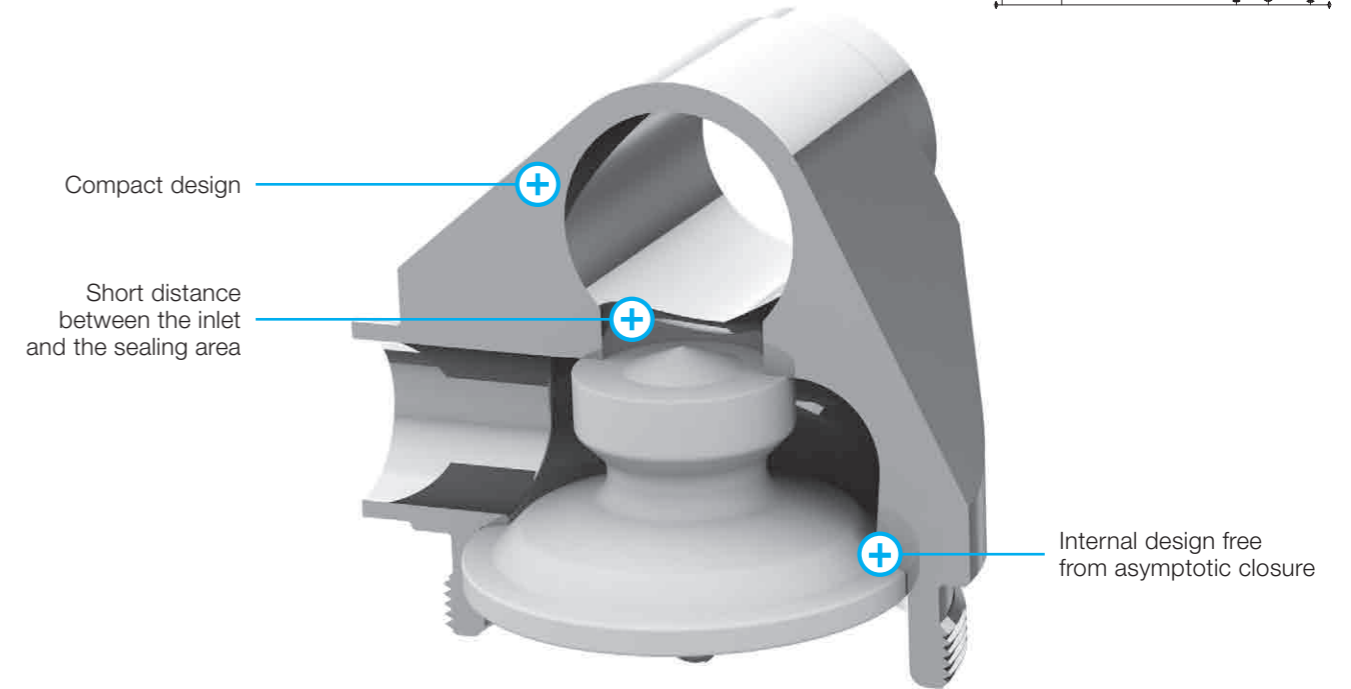
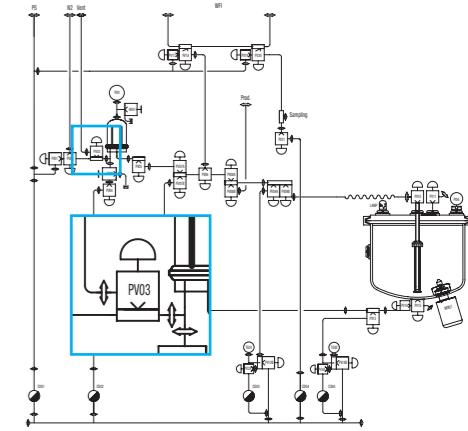
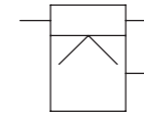
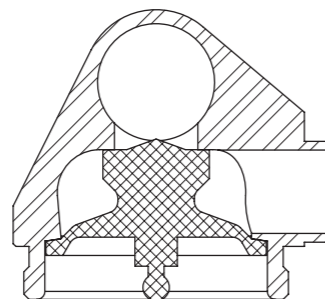

Standard CAD Valve body configuration examples: shut-off, flow through, shut-off + satellite, double opposite shut-off.



## VALVES ON PIPE - TANGENTIAL CLOSURE

**CAD SOLUTION.** CAD Tangential On Pipe Valves, are the answer where full drainability of the main pipeline is required in a horizontal assembly of the valve. In this design, the valve inlet which is always in close correspondence to the valve closure point, is tangential to the lower internal level of the pipe. This allows for the complete draining of the main pipe down to the last drop. For easier connection and space saving, the valve outlet will be vertical, compared to valves with additional elbows at the outlet. As with the case of most CAD solutions, it is available in the full product range: different valve sizes for each pipeline, Shut-Off, Flow Through, with or without satellite for downstream sterilization. Ideal for feed-in pipe, take-off or sampling from a pipe. CAD valves are able to fulfill all stringent applications for WFI and PW distribution loops.

Example of conventional design

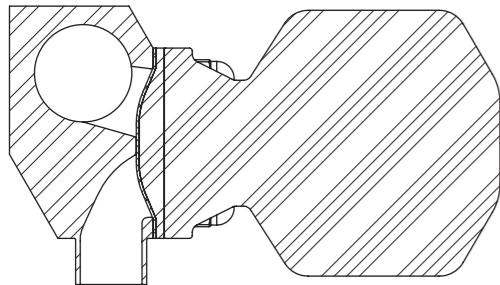

CAD design

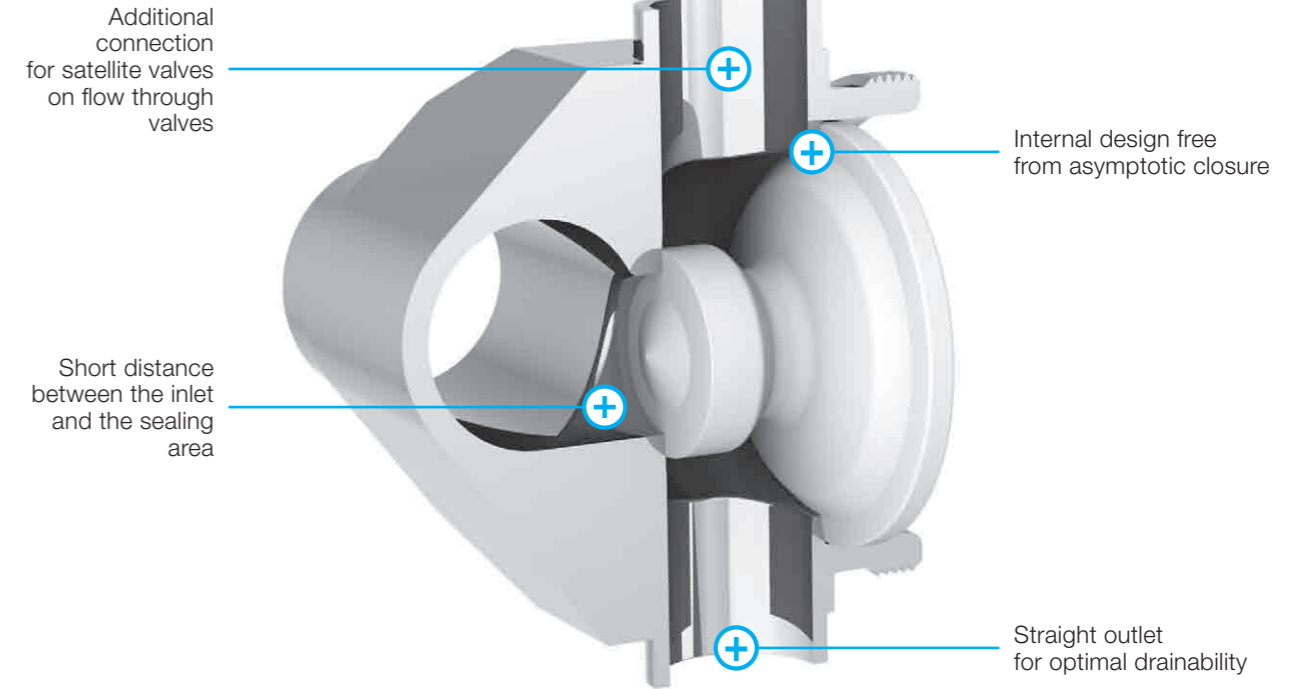
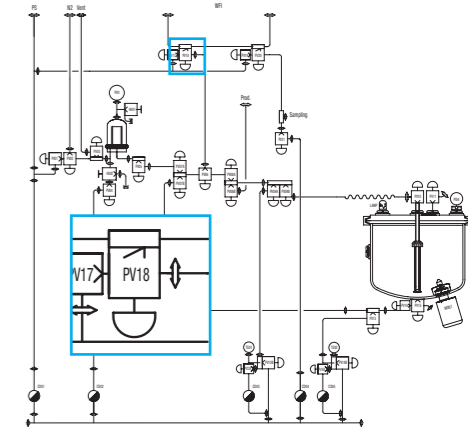
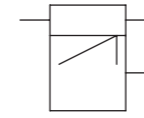
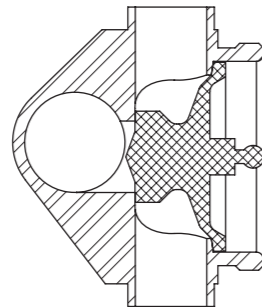

Standard CAD Valve body configuration examples: shut-off tang. on pipe, shut-off tang. on pipe + satellite, flow through tang. on pipe.



## PROCESS ASSEMBLY: POINT OF USE

Typically complete point of use valves on pharmaceutical water loops for aseptic processing are comprised of a main user valve, a sampling valve and two additional satellite valves for downstream sterilization of both valves. Welding 4 valves together on a loop requires complex and expensive work that has to be done during the installation of the piping. This job usually has to be done with orbital welding machines to assure good weld quality. Components developed for orbital welding machines require long butt-weld ends which increases system volume. The positioning and orientation of the valves during installation can be very difficult and time consuming.

**CAD SOLUTION.** CAD Point of Use Assemblies are the answer to the highest demands in terms of efficiency and compact design. Using precision machining capabilities, all the required valves can be machined from a single block, thus keeping the system's dimension to the absolute minimum. During the installation, only two connections have to be made to the main pipeline. The block can be delivered with ready to work steam Tri-Clamped inlets and outlets, saving hours of job site installation and achieving a level of quality not possible in the field. Several configurations are available. Our process experts will help you in the correct configuration according to your needs.

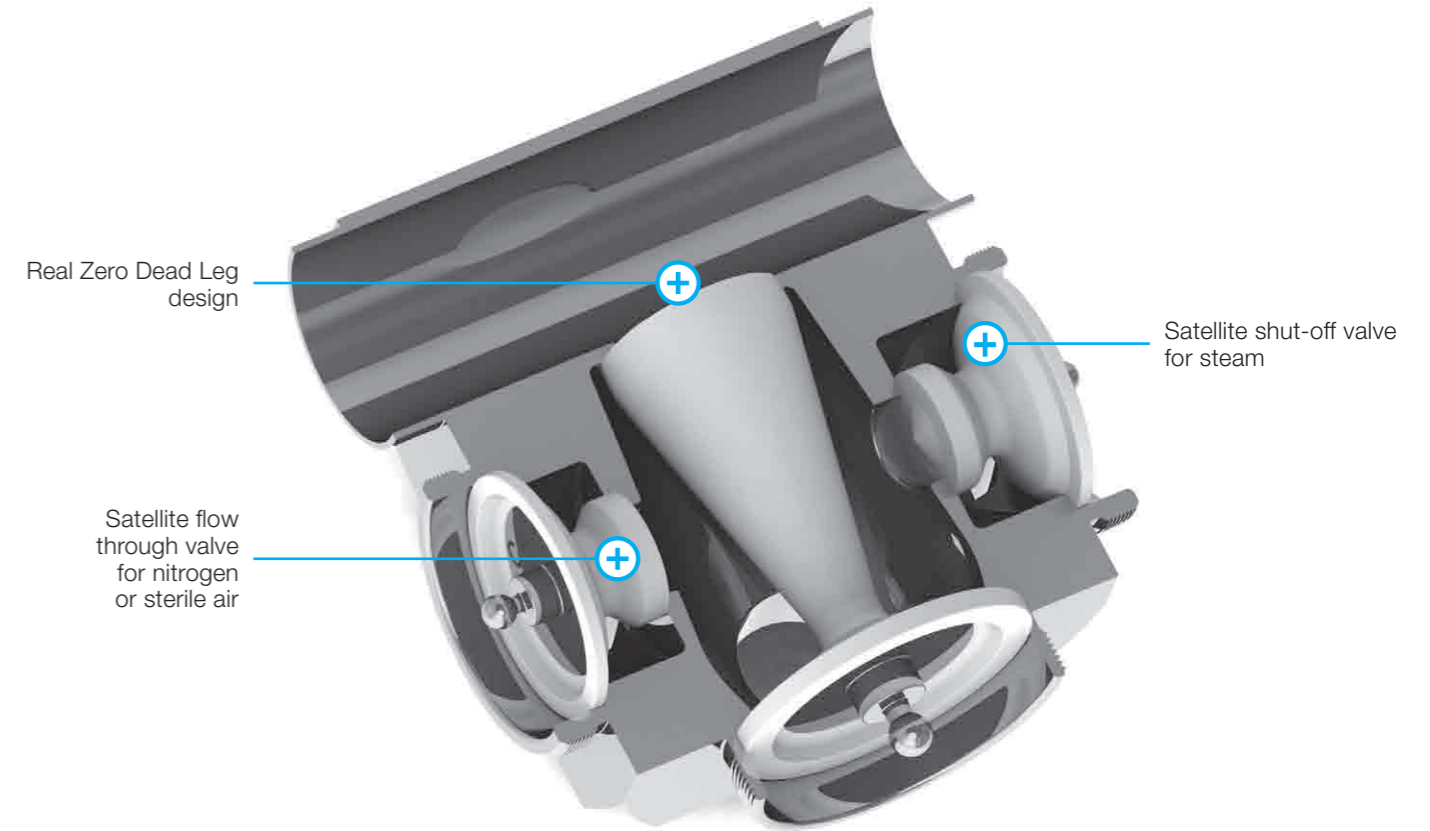
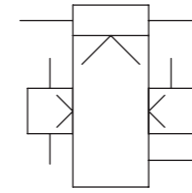

Standard CAD Point of Use Valve examples: point of use valve + satellite & sampling valve + satellite, extended point of use + flow through valve + shut off, all available on several dimensions and configurations.





## PROCESS ASSEMBLY: BOTTOM POINT ASSEMBLIES

Typical bottom point drains in pharmaceutical installations for aseptic processing are composed of a large CIP drain valve and a smaller valve for the condensate drain. These valves may have a common inlet, but the two outlets have to be separated and work alternately according to the upper running process: CIP or SIP. An additional connection has to be added and this connection should be as close as possible to the closure areas of the two valves in order to connect the temperature transmitter. This close coupling allows accurate detection of the temperature level on the lower part of the installation to be sure that during SIP cycles, the entire system is running at the required temperature. Welding of all the components of this system together require repetitive and sometimes complex work due to the fact that the height available is often very limited.

**CAD SOLUTION.** CAD Bottom Point Assemblies are the answer to this need. Two different designs are available according to the requested steam trap. Both types are available in two main sizes: 3/4" valve for CIP drain valve + 1/2" for condensate drain valve or 1" CIP drain + 1/2" condensate drain. Both systems have all required Tri-Clamp connections and can be connected to the installation in few minutes, saving hours of on-site work and speeding the finishing of the installation. The CAD Bottom Point assembly will result in a very compact design with a final quality not possible when compared to the same work done with typical tools available during on-site or skid fabrication.

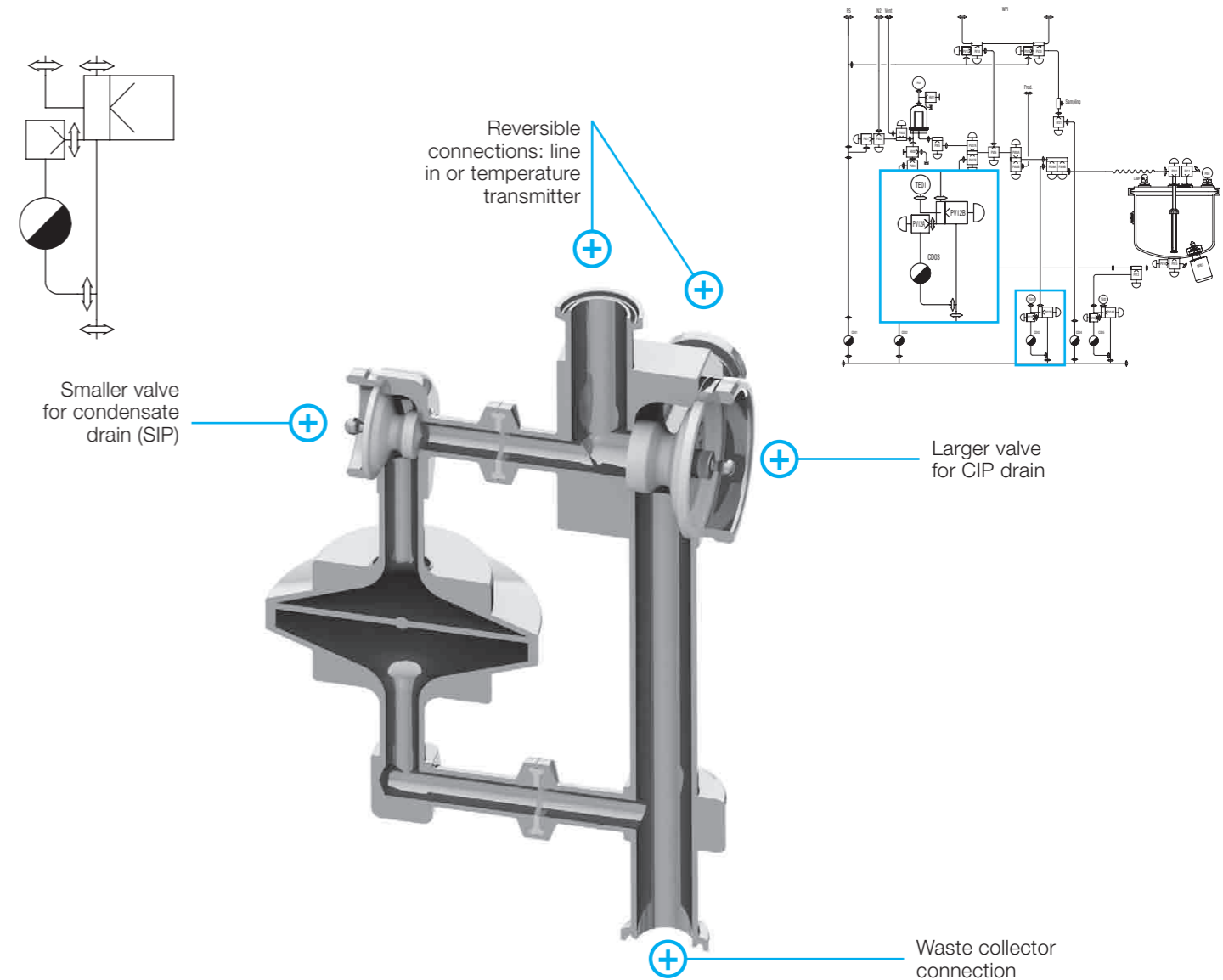

Standard CAD Bottom Point of Use assembly examples: 2 different configurations, both available on 2 dimensions, 3/4"+1/2" or 1"+1/2".



## PROCESS ASSEMBLY: DEEP TUBE SPRAY BALL

Typical pharmaceutical vessels require several connections on the top of the vessel and each for different purpose: product inlet, ventilation filter, water feed inlet, vacuum disk breaker, spray balls, sparger, etc... Unfortunately each connection presents a problem in terms of cleaning. For this reason, many times two spray balls are inserted inside the vessel. Managing this large number of connections, typically with welded ferrules and valves set far back from the inner tank surface requires frequent maintenance operations for cleaning reasons.

**CAD SOLUTION.** Following the CAD philosophy, by adding the CAD Deep Tube Spray Ball, the total number of connections on the top dish can be drastically reduced. This simplifies design and improves the cleanability of the vessel. Tank filling, SIP, CIP and gas bubbling can be done with just one tool, using only one connection.

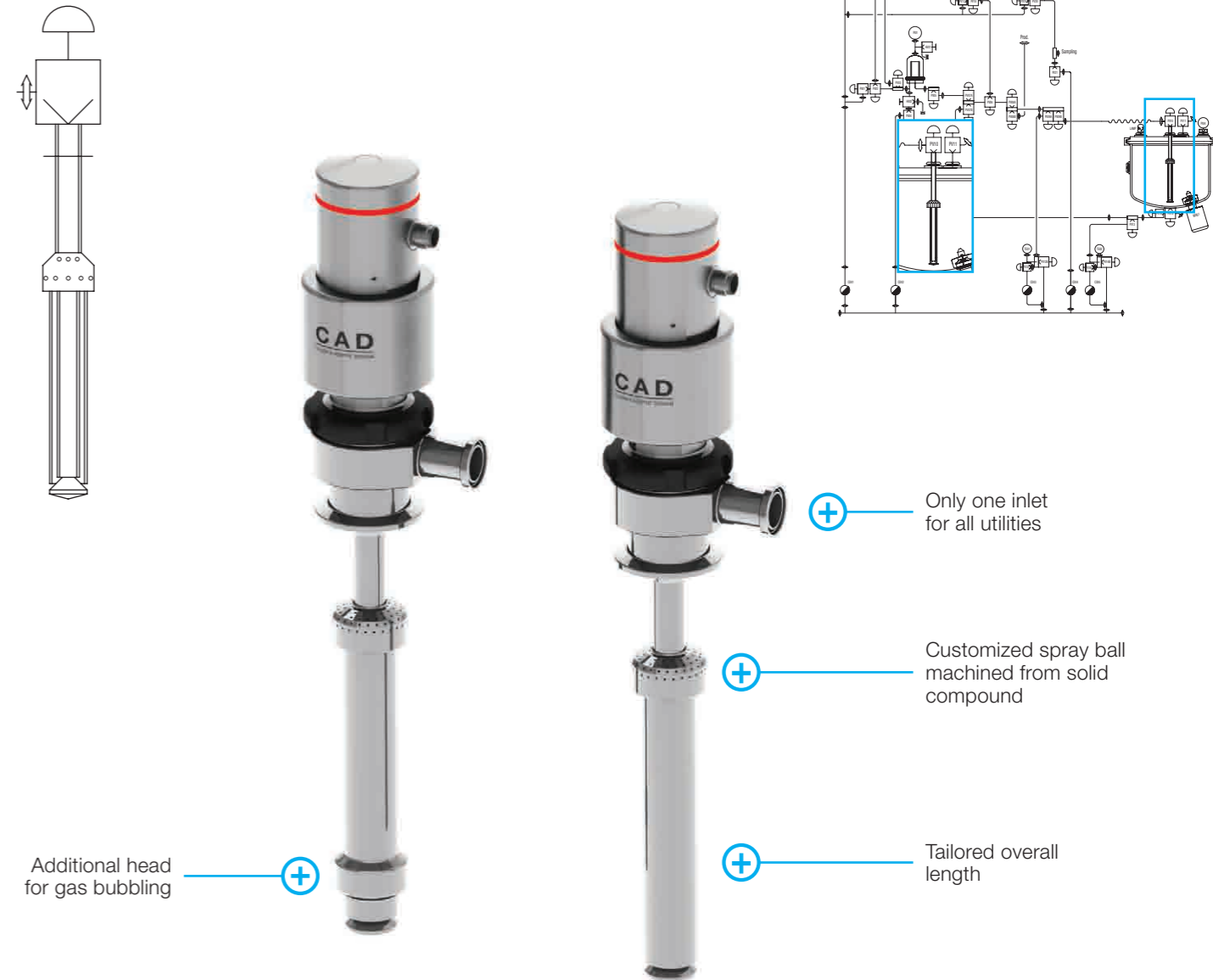

2 versions, both available in several dimensions: 2 functions for feed in/SIP + CIP or 3 functions for feed in/SIP + CIP + gas bubbling.

## ACTUATORS

The most stringent demands in aseptic processing typically require the use of stainless steel and PTFE due to almost universal compatibility. During external cleaning process, plastic handles can be damaged. Plastic pneumatic actuators are large compared to what is possible with a stainless actuator. During SIP operations the heat can compromise the functionality of these systems. Also position detecting sensors on actuators made of plastics have limited operating range in terms of temperature resistance.

**CAD SOLUTION.** CAD manual actuators are made from stainless steel with PTFE handles and are fully autoclaveable. Pneumatic actuators are made of stainless steel. CAD Double Position Sensors are made from stainless steel and are fully programmable without mechanical adjustment via PLC or via the CAD Programmer. Two kinds of extended handles are available for bottom tank valves and for both types the Double Position Sensor can be connected.



CAD actuators: manual straight, manual 90° short or extended, pneumatic NC, NO, or double effect, modulating.



## DIAPHRAGMS

For some applications a standard radial valve is still not enough to achieve closures with a zero dead leg. For these special applications, such as cryogenic vessels, fully jacketed vessels and pipe take-off applications the potential dead legs could reduce performance during SIP and CIP cycles.

**CAD SOLUTION.** From its engineering birth, CAD diaphragms have been developed for all sizes valves, from half inch up to four inch, and in two lengths: short and extended. Thanks to this idea, dead legs can now be eliminated in places where it has not been possible before today.

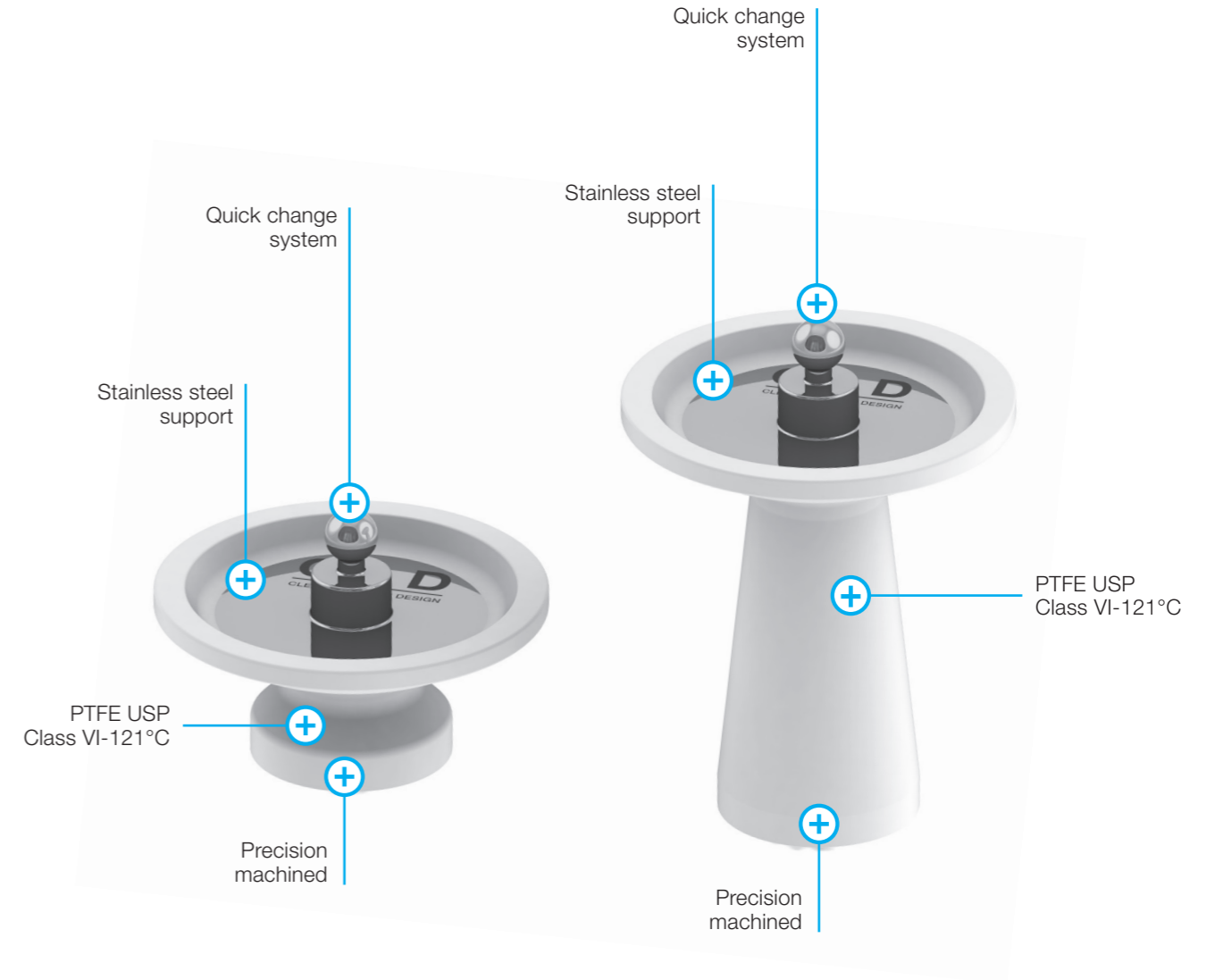

CAD diaphragms: short or extended, both available from 1/2" up to 4"

## UPGRADE

During the design and manufacturing of a new installation, reduction of the external dimensions as well as the internal volume should be a priority in order to optimize the performance of the entire system. The CAD valve range has been engineered to allow designers of modern aseptic process systems to achieve a minimum distance between actuators, often just few millimeters.

**CAD SOLUTION.** For applications, such as at the outlet of bottom tank valves or for an instrument connection, an elbow with TC connection or long butt weld ends for orbital welding may be needed. For this reason, a wide product range of additional high quality connections are available that can be ordered to match your specifications: straight, 45°, 90°, butt-weld or Tri-Clamp. This will result in quality improvement and time savings.



CAD upgrades: straight, 45°, 90°, butt-weld ends or Tri-Clamp, all available from 1/2" up to 4"

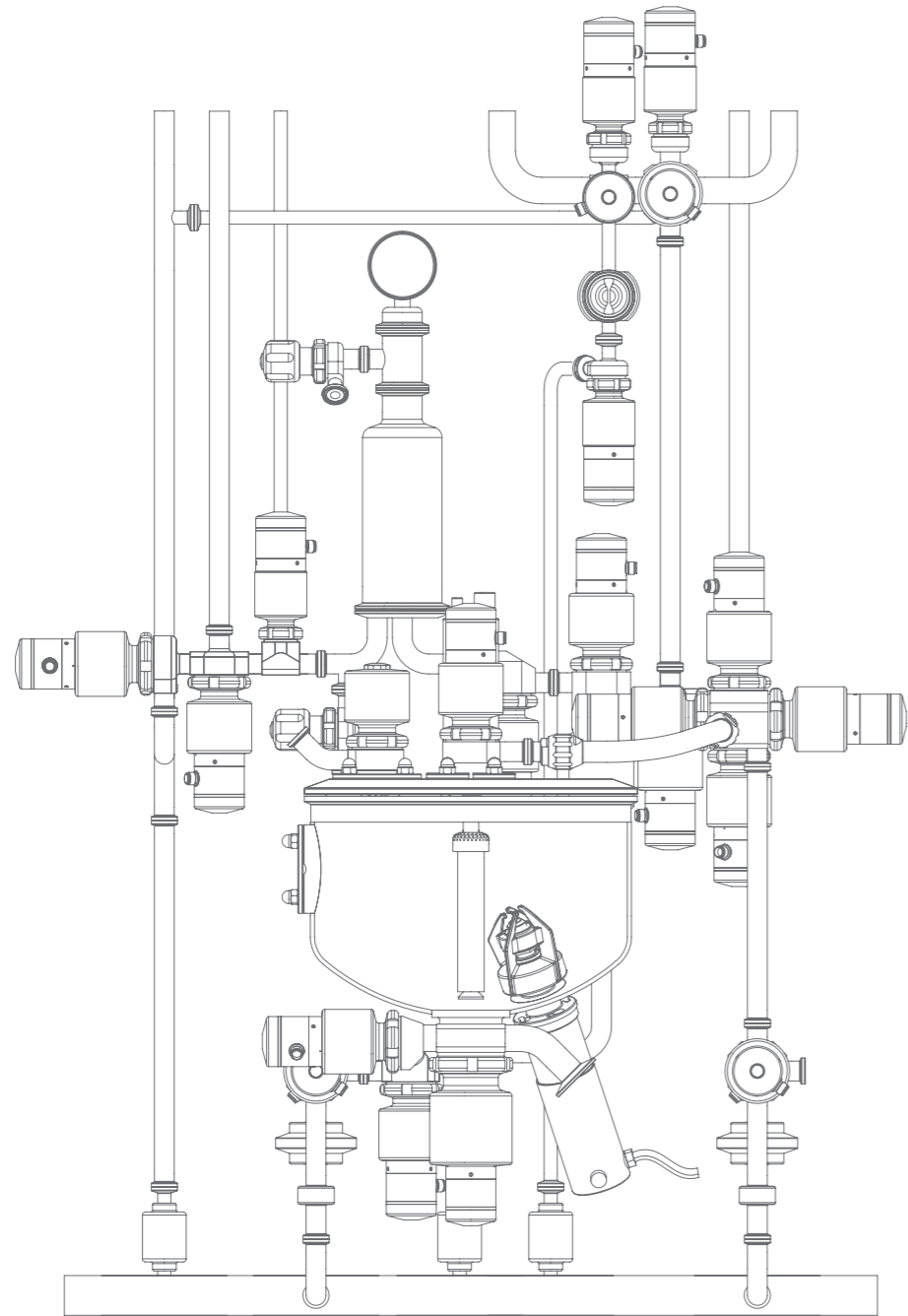



Contacto en España y  
Portugal:

Juan Solá

T: +34 620 838 814

[info@halltech.biz](mailto:info@halltech.biz)

[www.halltech.biz](http://www.halltech.biz)



**Rattiinox s.r.l**

Via Mara, 44 22066 Mariano Comense (Como) Italy

**T** +39.031.3551263 **F** +39.031.3554509

[www.rattiinox.com](http://www.rattiinox.com) [info@rattiinox.com](mailto:info@rattiinox.com)